

EN-1200s

适用注塑机吨位：350~550ton
Injection Press Range:350~550ton



EN-1200



STEC-XC1

全新操作盒 性能提升

New pendant with improved performance
搭配电容式触摸屏，实现智能操作
Equipped with capacitive touch screen, realized intelligent operation

综合参数 | GENERAL SPECIFICATIONS

电源 Power Source	常用气压 Air Pressure	驱动方式 Drive System	姿势(气缸) Posture (Air Cylinder)	气动姿势部推力(气压: 0.5Mpa时) Air Cylinder Driving Force (Air Pressure at 0.5Mpa)		控制箱 Control Box
				最大可搬重量 Max. Load	姿势力矩 Posture Torque	
AC200V+20% / -10% 50/60Hz(单相) Single Phase	0.5Mpa	AC伺服马达 AC Servo Motor	90° 固定 90° Fixed	标准姿势部：10kg (含夹具重量) Incl. Chuck Weight	20.6N·m	STEC-XC1

机种 Model	行程(移动量) (mm) Stroke				电源设备容量 (KVA) Electric Consumption	最大消费电力 (KW) Max Power Consumption	机器重量(kg) Net Weight		空气消耗量 (Nl/周期) Air Consumption (Nl/Cycle)
	制品上下 Ⓟ Vertical	水口上下 Ⓡ Vertical	前后 Crosswise	走行 Traverse			本体 Main Body	操作盒 Pendant	
EN-1200	1200	—	131~1100	1800 [1600] [2000] [2200]	2.9	1.7	353.7	1.6	4.5
EN-1200s		1250	Ⓟ 300~1100 Ⓡ 123~923		3.5	2.1	369.7		

○ [] 尺寸表示选项行程。

○ 本体重量包括控制箱及电线的重量。

○ Ⓟ 表示制品侧手臂，Ⓡ 表示水口侧手臂。

○ Figure in [] shows option stroke.

○ Net weight includes the weight of interlock box and driver box.

○ In the column of stroke, Ⓟ stands for product side arm and Ⓡ stands for runner side arm.

标准功能 | STANDARD FUNCTIONS

取出侧 Product Extract Side	<input checked="" type="checkbox"/> 取出下降待机 Delayed arm descent	<input checked="" type="checkbox"/> 前进取出侧姿势控制 Crosswise product extract side posture control	<input checked="" type="checkbox"/> 吸着确认单元(1回路) Vacuum confirmation unit (1circuit)	<input checked="" type="checkbox"/> 自由滑移取出 Free extract for under-cut mold
	<input checked="" type="checkbox"/> 顶针联动 Ejector link	<input checked="" type="checkbox"/> 顶针后退联动 Ejector return link	<input checked="" type="checkbox"/> 水口模内开放 Runner release within mold	<input checked="" type="checkbox"/> 前后自由伺服点 Crosswise free servo point
走行 Traverse	<input checked="" type="checkbox"/> 走行途中姿势 Posture control during traverse	<input checked="" type="checkbox"/> 浇口途中落下(走行·复归) Midway sprue release (Traverse·Return)	<input checked="" type="checkbox"/> 不良品排出 Defective product reject	
	<input checked="" type="checkbox"/> 横走行待机 Delayed traverse	<input checked="" type="checkbox"/> 水口途中开放(走行·复归) Midway runner release (Traverse·Return)	<input checked="" type="checkbox"/> 初期成型品排出 Initial products release	
落下侧 Product Release Side	<input checked="" type="checkbox"/> 落下侧下降途中姿势 Posture midway descent at release side	<input checked="" type="checkbox"/> 装箱点(各轴256点) Point packaging (Max 256 points)	<input checked="" type="checkbox"/> 自由装箱点(8级, 共1024点) Point free packaging (8 stage, 1024 points)	<input checked="" type="checkbox"/> 输送带启动信号 Start signal of conveyor
	<input checked="" type="checkbox"/> 3国语言切换(中文、日文、英文) Three language exchange (Chinese, Japanese, English)	<input checked="" type="checkbox"/> 保养功能 Maintenance feature	<input checked="" type="checkbox"/> 外部存储记忆 External storage memory	<input checked="" type="checkbox"/> 伺服休眠 Servo sleep feature
其它 Other	<input checked="" type="checkbox"/> 伺服监视 Servo monitor	<input checked="" type="checkbox"/> 背景灯自动OFF Backlight Auto OFF	<input checked="" type="checkbox"/> USB通信端口 USB communication port	<input checked="" type="checkbox"/> 操作权限分级管理 Operation authorization management
	<input checked="" type="checkbox"/> 标准搭载成型机自动监视模式 Carrying with auto monitor mode	<input checked="" type="checkbox"/> 分步教示功能 Step by step Teaching function	<input checked="" type="checkbox"/> 生产支援功能 Production control feature	<input checked="" type="checkbox"/> 数据管理 Data management

取出侧 Product Extract Side	<input type="checkbox"/> 制品确认2回路/4回路 Pro confirmation 2 circuits/4circuits	<input type="checkbox"/> 夹具内剪刀回路 Air nipper in chuck	<input type="checkbox"/> 夹具内剪刀(带引拔) Air nipper in chuck (W/Pull)
	<input type="checkbox"/> 回转机构(I, II, III, IV) Product rotation unit (I,II,III,IV)	<input type="checkbox"/> 吹气回路(模具) Air blow circuit(mold)	
落下侧 Product Release Side	<input type="checkbox"/> 制品2点/4点开放 Release product at two/four different points	<input type="checkbox"/> 吸着2点/4点开放 Release products at two/four different points W/Vacuum	<input type="checkbox"/> NT剪切·可动侧(无单元, 带电磁阀) NT gate cut on crossmember of moving side (W/O unit,W/Valve unit)
			<input type="checkbox"/> NT剪切·可动侧(有单元, 带电磁阀) NT gate cut on crossmember of moving side(W/ unit,W/Valve unit)
其它 Other	<input type="checkbox"/> 警报灯(红色, 无蜂鸣器) Alarm Lamp (Red color,w/o buzzer)	<input type="checkbox"/> 自动快速交换用夹具(气压式) Quick chuck change automatic (air sw)	<input type="checkbox"/> 欧规 12 (SPI) EUROMAP 12 (SPI)
			<input type="checkbox"/> 亚洲规格欧规 67(筒装版) EUROMAP 67(simple type)

外观尺寸 | OUTER DIMENSIONS

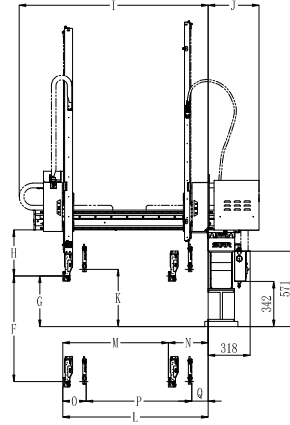
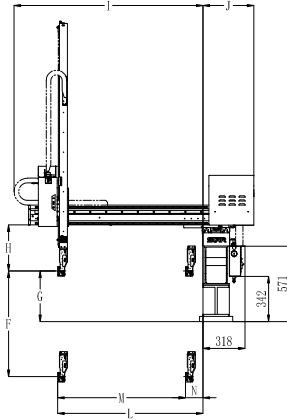
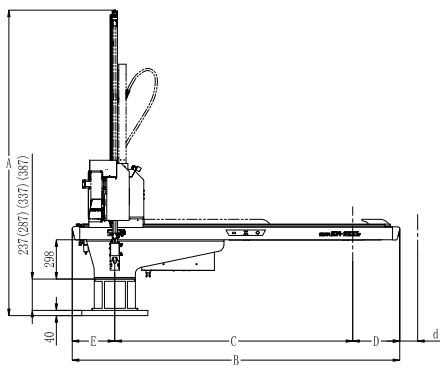

外形尺寸(mm) OUTER DIMENSIONS		EN-1200	EN-1200s	
A	全高 / Overall height	2273[2323] ^{*1} [2373] ^{*2} [2423] ^{*3}	2313[2363] ^{*1} [2413] ^{*2} [2463] ^{*3}	<p>○[] 内的尺寸表示选项行程。 ○水口夹的厚度为25mm。 ○姿势部厚度为74mm。但根据配管方式不同, 此尺寸多少会有些不同。 ○水口侧上下行程比制品侧上下行程长50mm。 ○*1表示C尺寸为1600mm。 ○*2表示C尺寸为2000mm。 ○*3表示C尺寸为2200mm。 ○*4表示G尺寸为434mm。 ○*5表示G尺寸为484mm。 ○*6表示G尺寸为534mm。</p> <p>○Figure in [] shows option stroke. ○Thickness of runner chuck is basically about 25 mm. ○Thickness of posture area is basically about 69 mm (depends on tubing) ○Runner side vertical stroke is 50 mm longer than that of product side. ○*1 When dimension C is 1600 mm. ○*2 When dimension C is 2000 mm. ○*3 When dimension C is 2200 mm. ○*4 When dimension G is 434 mm. ○*5 When dimension G is 484 mm. ○*6 When dimension G is 534 mm.</p> <p>※反操作时E值为364、[564]^{*1}、[564]^{*2}、[364]^{*3} D值为315</p> <p>※As anti-operator side E is 364、[564]^{*1}、[564]^{*2}、[364]^{*3} D is 315</p> <p>※d值正操作时为0 反操作时为0、[0]^{*1}、[4]^{*2}、[4]^{*3}</p> <p>※As operator side d is 0 anti-operator side d is 0、[0]^{*1}、[4]^{*2}、[4]^{*3}</p>
B	全宽 / Overall width	2479[2479] ^{*1}	[2879] ^{*2} [2879] ^{*3}	
C	走行行程 / Traverse stroke	1800[1600] ^{*1} [2000] ^{*2} [2200] ^{*3}		
D	落下侧突出位置 / Overhang, release side		357	
E	取出侧突出位置 / Overhang, product side	322[522] ^{*1} [522] ^{*2} [322] ^{*3}		
F	Ⓟ 制品侧上下行程 / Ⓟ Vertical stroke		1200	
G	Ⓟ 制品侧上下待机位置 / Ⓟ Vertical standby	384[434] ^{*1} [484] ^{*2} [534] ^{*3}		
H	夹具安装位置上方有效尺寸/Bottom of crosswise to chuck mount position		349	
I	前后单元 / Crosswise arm		1429	
J	本体厚度 / Thickness		426	
K	Ⓟ 水口侧上下待机位置 Ⓟ Vertical standby	—	434[484] ^{*1} [534] ^{*2} [584] ^{*3}	
L	Ⓟ 制品前进MAX Ⓟ Crosswise reach max		1100	
M	Ⓟ 制品前后行程MAX Ⓟ Crosswise stroke max	969	800	
N	Ⓟ 制品前后待机MIN Ⓟ Crosswise stroke max	131	300	
O	Ⓟ Ⓟ 制品臂、水口臂接近MIN Ⓟ Ⓟ Proximity min	—	177	
P	Ⓟ Ⓟ 水口侧前后行程MAX Ⓟ Crosswise stroke max	—	800	
Q	Ⓟ Ⓟ 水口侧前后待机MIN Ⓟ Crosswise standby min	—	123	

●因改良等原因, 规格及外观有所变更时, 不再另行通知, 敬请包涵。All stated here is subject to change without advance notice.



华东地区

- 大陆地区总部: 星精机械(上海)有限公司
 地址: 上海市徐汇区桂平路555号46栋208室
 ☎ +86-021-5423 4571
- 苏州事务所☎+86-0512-6805 8385
 - 厦门事务所☎+86-0592-577 9994
 - 余姚事务所☎+86-0574-6253 2721
 - 青岛分公司☎+86-0532-5556 5517

华北/东北地区

- 天津分公司☎+86-022-5838 7675
- 大连分公司☎+86-0411-8756 2176

华南/西南/华中地区

- 深圳分公司☎+86-0755-2962 2620
- 广州分公司☎+86-020-3708 4205
- 武汉分公司☎+86-027-8425 3500
- 重庆分公司☎+86-023-6036 0877
- 成都分公司☎+86-028-6549 5545
- 襄阳生产工厂☎+86-0710- 3311 813

港澳台地区

- 香港公司☎+852-2687 6745
- 中日龙股份有限公司(台北市)
.....☎+886-2-2836 0039
- 台南营业所☎+886-6-273 8985
- 台中营业所☎+886-4-2463 1361